

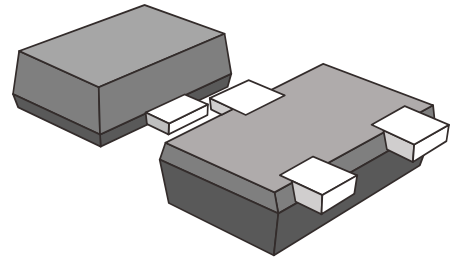

Features

- 56 Watts peak pulse power ($t_p = 8/20\mu s$)
- Bidirectional and unidirectional configurations
- Solid-state silicon-avalanche technology
- Low clamping voltage
- Low leakage current
- Low capacitance ($C_j=0.45$ pF typ.)
- Protection two data lines:
- IEC 61000-4-2 $\pm 25V$ contact $\pm 25kV$ air
- IEC 61000-4-4 (EFT) 40A (5/50ns)
- IEC 61000-4-5 (Lightning) 4A (8/20 μs)



Applications

- Supports USB 3.0 data rates (5 Gbps)
Ultra low capacitance: 0.45pF typical I/O to GND
- Dataline
- Automatic Teller Machines
- Net works
- Power line

Mechanical Data

- SOT-723 package
- Molding compound flammability rating: UL 94V-0
- Packaging: Tape and Reel
- RoHS/WEEE Compliant

Schematic & PIN Configuration

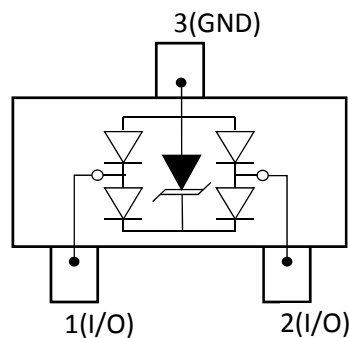

SOT-723

Pin Configuration and Functions

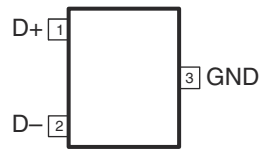

DRT Package 3-Pin SOT Top View

Pin Functions

PIN			TYPE	DESCRIPTION
NAME	DRT	DQA		
D1+	1	1	ESD port	High-speed ESD clamp, provides ESD protection to the high-speed differential data lines.
D1 -	2	2		
D2+	—	4		
D2 -	—	5		
GND	3	3, 8	GND	Ground
N.C.	—	6, 7, 9, 10	—	Not normally connected

Specifications

Absolute Maximum Ratings

over operating free-air temperature range (unless otherwise noted)⁽¹⁾

	MIN	MAX	UNIT
IO voltage (D+ and D- pins)	0	5	V
IEC 61000-4-5 surge current ($t_p = 8/20 \mu s$)		4	A
IEC 61000-4-5 surge peak power ($t_p = 8/20 \mu s$)		56	W
T _A Operating free-air temperature	- 40	85	°C
T _{stg} Storage temperature	- 65	125	°C

- (1) Stresses beyond those listed under Absolute Maximum Ratings may cause permanent damage to the device. These are stress ratings only, and functional operation of the device at these or any other conditions beyond those indicated in the operational sections of the specifications is not implied. Exposure to absolute maximum-rated conditions for extended periods may affect device reliability.

ESD Ratings

		VALUE	UNIT
V _(ESD)	Electrostatic discharge		
	Human body model (HBM), per ANSI/ESDA/JEDEC JS-001, all pins ⁽¹⁾	2500	V
	Charged device model (CDM), per JEDEC specification JESD22-C101, all pins ⁽²⁾	1500	
	IEC 61000-4-2 Contact Discharge	D+, D - pins	
IEC 61000-4-2 Air-Gap Discharge	D+, D - pins	9000	

(1) JEDEC document JEP155 states that 500-V HBM allows safe manufacturing with a standard ESD control process.

(2) JEDEC document JEP157 states that 250-V CDM allows safe manufacturing with a standard ESD control process.

Recommended Operating Conditions

over operating free-air temperature range (unless otherwise noted)

	MIN	MAX	UNIT
T _A operating free-air temperature	- 40	85	°C
Operating Voltage	0	5.0	V

Thermal Information

THERMAL METRIC ⁽¹⁾		SEST723U0513PA		UNIT
		DRT (SOT)		
		3 PINS		
R _{θJA}	Junction-to-ambient thermal resistance	610.2		°C/W
R _{θJC(top)}	Junction-to-case (top) thermal resistance	288.0		°C/W
R _{θJB}	Junction-to-board thermal resistance	118.4		°C/W
ψ _{JT}	Junction-to-top characterization parameter	20.2		°C/W
ψ _{JB}	Junction-to-board characterization parameter	116.4		°C/W
R _{θJC(bot)}	Junction-to-case (bottom) thermal resistance	N/A		°C/W

(1) For more information about traditional and new thermal metrics, see the *Semiconductor and IC Package Thermal Metrics* application report, [SPRA953](#).

Electrical Characteristics

Parameter	Symbol	Conditions	Min	Typ	Max	Units
Breakdown Voltage	V_{BR}	$I_T = 1mA$	6			V
Reverse Leakage Current	I_R	$V_{RWM} = 5V$		0.001	0.1	uA
Clamping Voltage	V_C	$I_{PP} = 4A$, 8/20 μs		12	14	V
Junction Capacitance between I/O pins	C_O	$V_{DC} = 0V$, $f = 1MHz$		0.25	0.35	pF
Junction Capacitance between I/O pin and GND	C_J	$V_{DC} = 0V$, $f = 1MHz$		0.45	0.6	pF

Electrical Parameters (TA = 25 °C unless otherwise noted)

Symbol	Parameter
I_{PP}	Maximum Reverse Peak Pulse Current
V_C	Clamping Voltage @ I_{PP}
V_{RWM}	Working Peak Reverse Voltage
I_R	Maximum Reverse Leakage Current @ V_{RWM}
V_{BR}	Breakdown Voltage @ I_T
I_T	Test Current

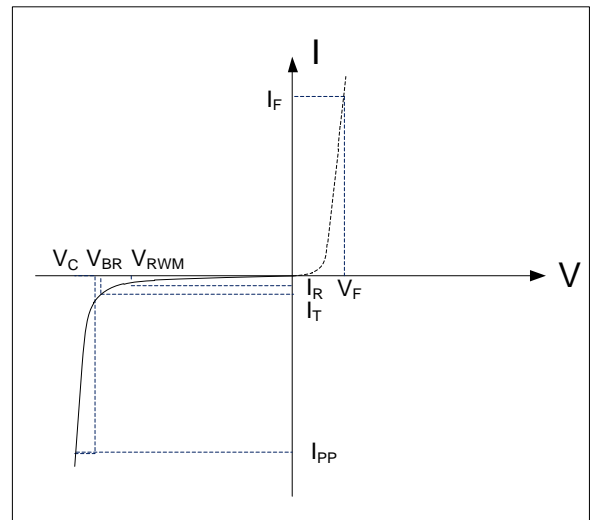

Note: 8/20 μs pulse waveform.

Typical Characteristics

Figure 1: Peak Pulse Power vs. Pulse Time

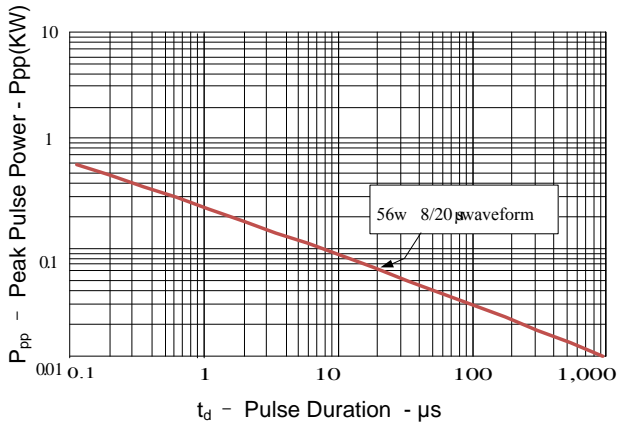

Figure 2: Power Derating Curve

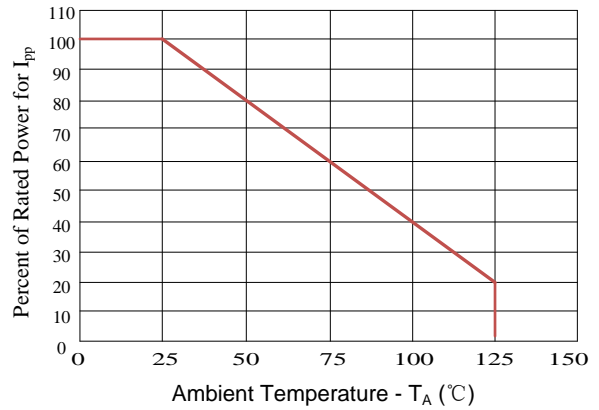

Figure 3: Pulse Waveform

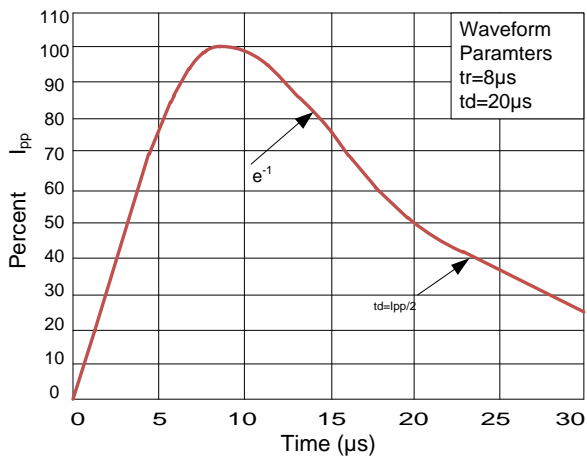
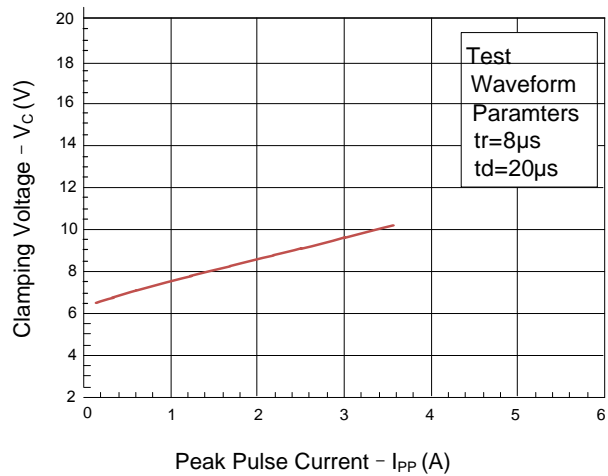
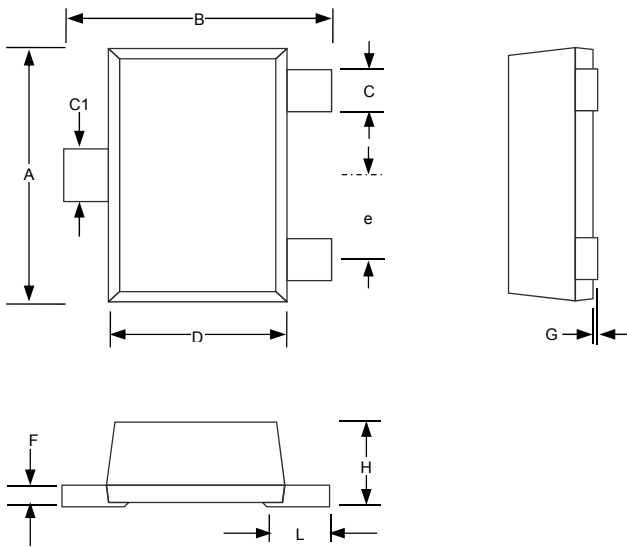

Figure 4: Clamping Voltage vs. I_{pp}



Outline Drawing – SOT-723



SOT-723						
SYMBOL	Millimeters			Inches		
	MIN	NOM	MAX	MIN	NOM	MAX
A	1.15	1.2	1.25	0.045	0.047	0.049
B	1.15	1.2	1.25	0.045	0.047	0.049
C	0.15	0.2	0.25	0.006	0.008	0.01
D	0.75	0.8	0.85	0.03	0.031	0.033
e		0.4			0.016	
F	0.08	0.1	0.15	0.003	0.004	0.006
G			0.05			0.002
C1	0.2	0.25	0.3	0.008	0.01	0.012

Marking

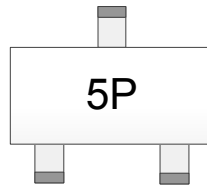

Ordering information

Order code	Package	Base qty	Delivery mode
SEST723U0513PA	SOT-723	10k	Tape and reel